

Patrick M. Crowley – Amir Habibdoust

# Assessing the exchange rate exposure of US multinationals



EUROJÄRJESTELMÄ  
EUROSYSTEMET

Bank of Finland Research  
Discussion Papers  
34 • 2013

# **Assessing the Exchange Rate Exposure of US Multinationals**

**by**

**Patrick M.Crowley,  
Texas A&M University – Corpus Christi,  
Texas, USA**

**and**

**Amir Habibdoust,  
University of Mazandaran, Faculty of Economics &  
Administrative Science, Babolsar, Iran**

**October, 2013**

## **Abstract**

This paper aims to examine the relationship between exchange rate movements and the stock return of firms at different time horizons by employing wavelet analysis. In particular, we use the maximum overlap discrete wavelet transform (MODWT) to decompose the exchange rate movement and the US firm's stock return over the period January 2006 to July 2012. The results reveal that at longer horizons not only does the number of firms which are exposed to exchange rate volatility increase but also the degree of exchange rate exposure increases. What is more, the sensitivity to exchange rate volatility is stronger at longer horizons for importing firms than for exporting firms, which shows an asymmetry in the usage of hedging strategies between importers and exporters.

**Key words:** Discrete Wavelet analysis, Exchange Rate Volatility, Hedging strategy

**JEL Classification:** C32, F31, F23

## **1. Introduction**

The study of exchange rate movements has a long history in economics at both the micro and macro level, not only because currency movements have an important role in macroeconomic policymaking but also because they also play an important role in microeconomic decision-making. At the microeconomic level, it is well known that firms are exposed to exchange rate risk which can severely affect cash flow and profitability. In this regard, financial managers are routinely involved in exchange rate risk management to secure the firm's profitability, and by extension this should be apparent in the stock price and consequent stock return for publically traded companies.

This study seeks to uncover information which can be hidden at different frequencies and attempts to expand our understanding of the time horizon and scale level (frequency) role in determining the relationship between exchange rate movements and stock return at firm level. Clearly hedging strategies are available in the short run, but are rarely applicable to the medium and longer term, so that any exchange rate misalignment will still impact profitability over these time horizons.

Our research differs from most standard approaches in an important and crucial way, in that we employ a time-frequency method to analyze the scale properties of the above-mentioned relationship. More specifically, in this regard, we employ discrete wavelet analysis. In the paper we aim to shed some light on the exchange rate exposure of U.S. firms from eight sectors by employing discrete wavelet analysis and basic regression analysis. In contrast to other traditional methods such as purely time-domain analysis (for example time series methods) and purely frequency-domain methods (such as Fourier analysis), the wavelet approach is a time-frequency method, so it enables us to simultaneously investigate data in both time and frequency domain.

The paper is organized as follows. In section two we review the existing literature while in section three we provide a brief overview of the mathematical basis of time-frequency analysis. The model and data are described in section four. The empirical

results of wavelet based regression are discussed in section five and concluding remarks are presented in section six.

## **2. Existing Literature**

The issue of exchange rate variability and its effect on the profitability of companies has long been studied by economists, but there remain some unanswered questions. It is clear that firms that are exposed to exchange rate risk will likely try to minimize those risks, but, are firms which don't operate in an international environment influenced by exchange rate movements? Other questions are what kinds of firms are more exposed to the exchange rate, and is there any similarity between countries in this matter or not?

In theory, a firm's profits should be affected by exchange rate movements, but empirical studies have found no significant effects from exchange rate fluctuations. As Bartram and Bodnar (2005) mention: "Our review of this research suggests that a majority of these studies still find significant exposures in just 10–25% of the cases (with marginally higher percentages for firms in open, export-oriented economies and nonlinear exposures), a level that still appears to be below the prior expectations of the researchers based upon theoretical and anecdotal predictions." It should be noted that Bodnar and Gentry (1993), Bartov and Bodnar (1994), Amihud (1994), Allayannis (1997), and Griffin and Stulz (2001), showed that the firms examined were not exposed in a serious and significant way, even when they were involved in international activities. In related literature, the apparent gap between the theory and empirical results has been labeled the "exchange rate exposure puzzle".

Although an enormous amount of research has been done on this issue, there is no consensus among economists. For instance, Choi and Prasad (1995) developed a model of firm valuation to investigate exchange rate exposure for U.S. multinational firms over the period 1978-1989. They found that only 15 percent of individual firms are exposed. Bartram (2002) employed a nonlinear model to compute the level of

exchange rate exposure in German industry in which he used data for 447 firms over the period 1981-1995, and found that there is a significant relationship between exchange rate movements and stock returns.

In order to explore this problem, economists have employed different methodological approaches. For example, Khoo (1994) and Bartram (2004) used trade weighted multilateral exchange rates for analyzing this issue. Bartram (2004) and Koutmos and Martin (2003) investigated non-linear exchange rate exposure. Booth and Rotenberg (1990) and Kiyimaz (2003) give attention to so-called "residual exposure". Some other researchers such as Amihud (1994), Bartov and Bodnar (1994), Donnelly and Sheehy (1996), Allayannis (1997) also used a lagged exchange rate variable in their studies.

A number of studies have concentrated on the time variation of exposure and the time horizon over which the exposure occurs, but they could not address and report any useful findings concerning time horizons. For instance, Allayannis (1996) mentions that in contrast to the largely insignificant exchange rate exposure at short horizons, at long horizons the exchange rate exposure is statistically very significant. These results suggest that the relationship is stronger when measured over a longer time horizon. Dominguez and Tesar (2006) investigated firms in eight industrial countries (excluding the USA) and found that exchange rate exposure increases as the time horizon increases.

A wide range of studies have been conducted using wavelet methodologies in economic and financial time series, for example Ramsey (1999, 2002) and Schleicher (2002), while Crowley (2007) provides an extensive review on wavelet analysis and its application in economics and finance. Other examples of wavelet analysis being employed to investigate economic and financial phenomena are Ramsey & Zhang, (1997), Ramsey and Lampart (1998), Gençay et al (2001), Kim and In (2005), and Gallegati (2008).

## 2. Time-Frequency Analysis

Here we provide a concise overview of the mathematical background of time scale analysis and the wavelet methodology. As mentioned previously, time-domain analysis cannot provide a proper basis for analysis when frequencies are changing; in other words, time-domain methods cannot reveal valuable and helpful information which are hidden in different frequencies. The most well-known frequency domain method is the Fourier Transform (FT). This method transforms time series data from the time domain to the frequency domain, but the problem with the FT is that the data is transformed into just the frequency domain, so there is no ability to simultaneously analyse relationships in both the time and frequency domains. Indeed, with the FT method the time series under consideration should be locally and globally stationary, but unfortunately this also imposes a limitation as a noticeable number of economic and financial time series are locally and globally non-stationary. This is because of trade-offs between the frequency resolution and time resolution (Weedon, 2003) and the FT cannot capture this properly. Although the Windowed FT is often used to address these shortcomings with the FT, it does so only partially, as it suffers from a further problem which lies in Heisenberg uncertainty principle.<sup>1</sup>

### 2.1. Wavelet Analysis:

Wavelet analysis has its roots in multi-scale decomposition, the so-called multiscale analysis or multiresolutional analysis, which was developed by Meyer (1986), Mallat (1989a,b), Strang(1989), and Daubechies (1986). Technically speaking, multiscale analysis is an approximation operation through a dense vector space (Hilbert space) with empty intersects from coarsest to less detailed information.

Following Mallat's explanation for the pyramid algorithm and multiresolutional analysis, a variable  $X(t)$  can be written as follows:

---

<sup>1</sup>For more information on orthogonal transforms see Wang (2012) pp461-481.

$$X(t) \approx s_j(t) + d_j(t) + d_{j-1}(t) + \dots + d_1(t) \quad (1)$$

Where  $d_j(t)$  are detail components (wavelet “crystals”),  $s_j(t)$  is a trend component (the wavelet “smooth”) and  $j$  stands for the number of scales. Figure 1 summarizes the discrete wavelet transform (DWT) process. A variable  $X(t)$  is filtered by a (low-pass) filter,  $l$ , and a wavelet (high-pass) filter at each step. In other words, we filter out information at a different set of frequencies in each step until we reach an approximated variable which contains only the trend. In this regard, in the first step  $X(t)$  is decomposed into  $d_1(t)$  ( - the high frequency part) and  $S_1(t)$  ( - the low frequency part); consequently, the decomposed signal at scale 1 ( $J=1$ ) can be written as follows:

$$X(t) \approx s_1(t) + d_1(t) \quad (2)$$

Then, the abovementioned process is performed on  $S_1(t)$  while the signal will be subsampled by 2, so that:

$$s_1(t) \approx s_2(t) + d_2(t) \quad (3)$$

This recursive procedure is continued until we reach scale  $J$ . So finally, we have a set of detailed variables (high frequency components or “crystals”) and a smoothed trend component (or the “smooth”) as in equation (1). This approach then enables us to simultaneously investigate the data in both the time and frequency domain.

It should be noted that there are many different wavelet functions, such as the Morlet, Mexican hat, Daubechies and so on, which can be approximated for use in the filtering process as pairs of low pass and high pass filters. In this paper, we employ a Daubechies 4-tap (D4) wavelet as the wavelet function, which is an asymmetric wavelet. What is more, we employ the Maximum Overlap Discrete Wavelet Transform (MODWT) as our method of time-frequency decomposition. As DWT suffers from two shortcomings, namely “dyadic data requirements and the fact that the DWT is non-shift invariant” (Crowley (2007)), MODWT is used as an alternative

method which addresses the aforementioned drawbacks and provides some other advantages.<sup>2</sup>

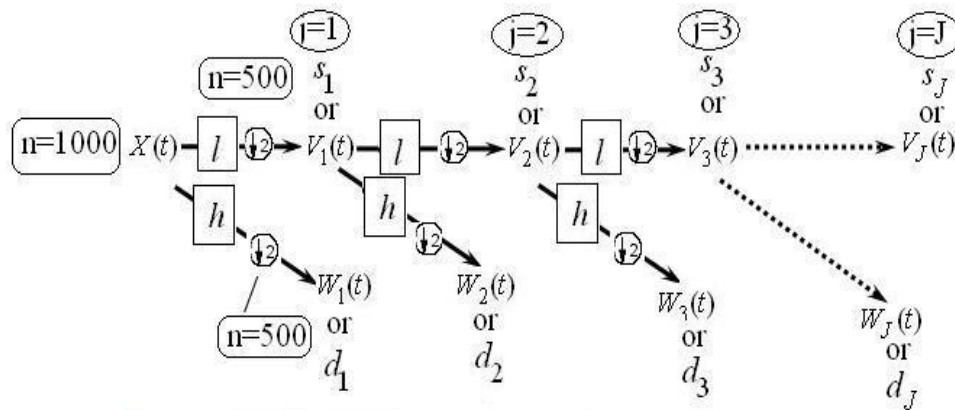

Figure 1- Discrete Wavelet Transform (DWT) Process

### 3. The Model and data set

In finance it is accepted that the value of a firm can be affected by a change in its cash flow. Movements in exchange rates are an undeniable source of a change in revenue cash flows, especially for firms which are directly involved in foreign operations. Indeed, an importing or exporting firm is directly influenced by currency appreciation and depreciation in terms of revenue generation. Multinational firms engage in both export and import activities at the same time, so they are clearly exposed to exchange rate risk over potentially both the short and the longer term. Obviously, firms take different strategies according to their goals, financial situation and other firm-specific issues, so some firms will hedge against short term movements in exchange rates by using offsetting financial derivatives. Hence, it is reasonable to say that the exchange rate can affect firms in dissimilar ways and also that the exchange risk sensitivity of firms will not be identical across all firms, even for those within the same industry.

To investigate the true nature of exchange rate exposure, therefore, analysis at the aggregate level doesn't lead us to appropriately assess the exchange risk sensitivity of

<sup>2</sup>For detailed information see Crowley (2007)



firm value. In other words, "A firm-level study is necessary to understand whether, and why, individual firms display varying sensitivity to exchange risk" (Choi and Prasad, 1995). According to the research in this literature, two regression models are most commonly used, one being the factor regression model, which is used by Adler and Dumas (1984), among others, and the other being the two factor model, which was introduced by Jorion (1990). The former assumes stock returns can be explained by exchange rate changes according to the following equation:

$$r_{i,t} = \beta_{0,i} + \beta_{1,i} \Delta e_t + \varepsilon_{i,t} \quad (4)$$

where  $r_{i,t}$  stands for firm (industry)  $i$ 's stock return at time  $t$ ,  $\Delta e_t$  is the percentage change in the exchange rate at time  $t$ , and  $\beta_{1,i}$  represents the sensitivity of the firm's stock return to exchange rate changes, otherwise known as the total exchange rate exposure coefficient. The total exchange rate exposure coefficient cannot capture exposure which is related to cash flow because other macroeconomic variables that are correlated with the exchange rate influence the exchange rate exposure. In other words, the correlation between the exchange rate and other macroeconomic factors (which influence all firms' value) create difficulties in interpretation of the exchange rate exposure variable. In order to remove this correlation impact and control for other macroeconomic factors, Jorion (1990) augmented the one factor regression model by adding a control variable, namely the return on market portfolio, to the exchange rate exposure regression model. What is more, by adding the return on the market portfolio, this reduces the residual variance of the regression in comparison with a one factor model. The 2 factor model can therefore be rewritten as follows:

$$r_{i,t} = \beta_{0,i} + \beta_{1,i} \Delta e_t + \beta_{2,i} r_{m,t} + \varepsilon_{i,t} \quad (5)$$

where  $r_{i,t}$  stands for the firm (industry)  $i$ 's stock return at time  $t$ ,  $\Delta e_t$  is the percentage change in exchange rate at time  $t$ ,  $r_{m,t}$  represents the return on the market portfolio, and  $\beta_{2,i}$  reflects the industry market beta, while  $\beta_{1,i}$  represents the exchange rate exposure coefficient.

By decomposing data into different scales, it will be possible to estimate this relationship over different frequency ranges. In this paper, we employ equation (5) as

our econometric specification to determine whether there is a negative or positive relationship between the exchange rate and a firm's stock return over different frequency ranges.

Our data set includes real exchange rate monthly data, which are taken from the Federal Reserve website, the DOW Jones total stock market return index, and 86 large U.S. firms which are taken from Dow Jones website. The dataset covers the period from January 2006 to July 2012.

The Real Broad exchange rate is a trade weighted US dollar index in which a weighted average of the value of a range of currencies relative to the U.S. dollar is employed. Additionally, it is adjusted by foreign inflation to make it a more informative measure of the US dollar's value. Although Williamson (2001) points out the drawbacks of using a trade weighted measure ( -it may be misleading if a firm is exposed to only a small number of currencies), it can be considered as an appropriate choice of variable because all of the firms in our sample are large firms so are therefore likely involved in a multitude of international activities.<sup>3</sup> Figure 2 plots the real broad exchange rate index and the decomposed components over the sample period.

---

<sup>3</sup> For more information see Choi and Prasad, 1995, Bodnar and Wong, 2003, and Dominguez and Tesar, 2005.

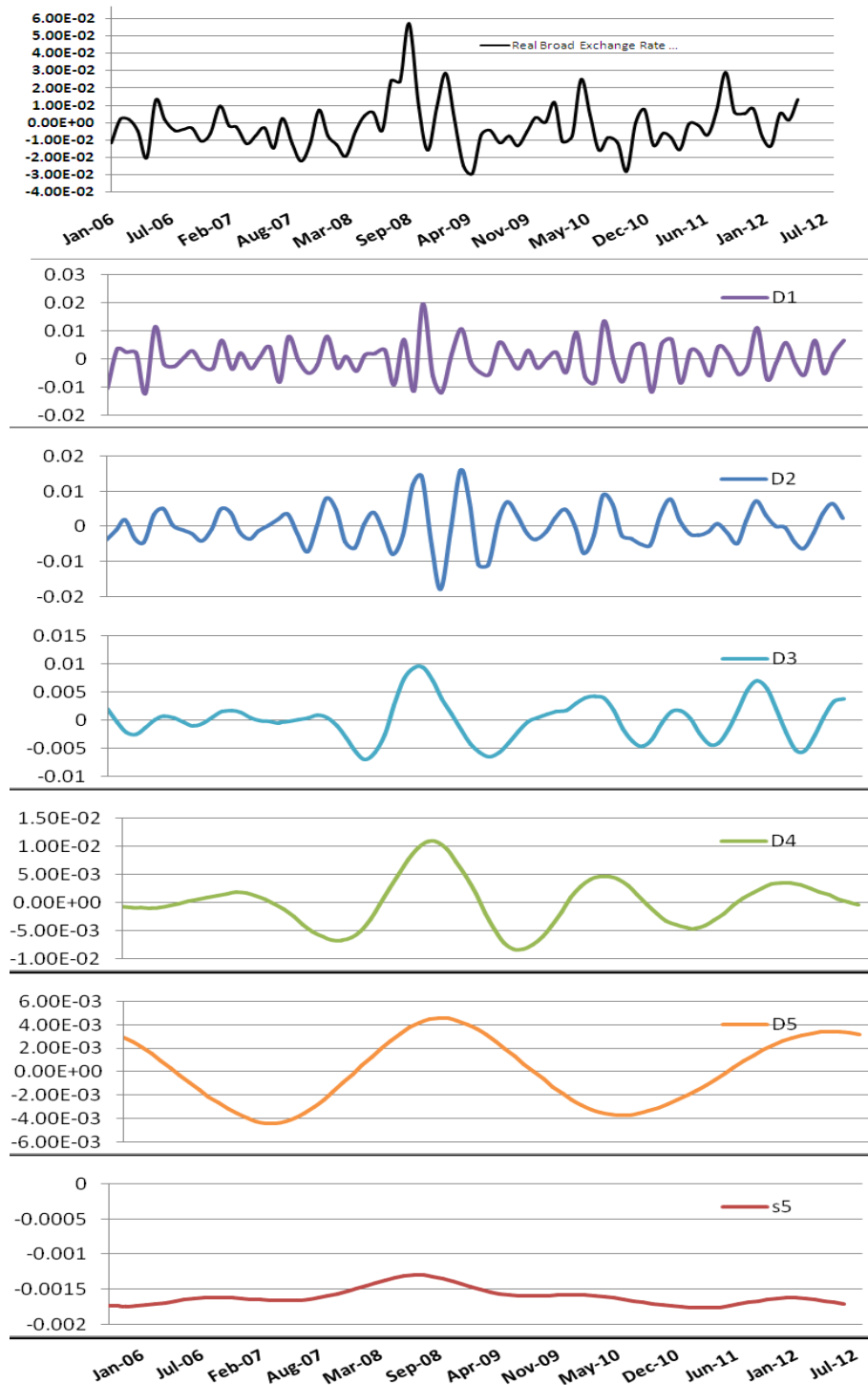

Figure 2. Real broad exchange rate index and decomposed components.

We select a value-weighted return index as a macroeconomic control variable (DOW Jones total stock market return) because it does not treat all firms equally; in other words, it gives more weight to larger firms; therefore, it is also a suitable choice in this instance.

We then select the firms for our study from the Dow Jones U.S. sectors fact sheets. We limited our selection to top components of each sector (excluding the financial sector) and to monthly stock price returns over the period January 2006 to June 2012. It is also noteworthy that this study focuses on recent years while other studies did not investigate this more recent period. By using these criteria, 86 firms are selected. Table 1 shows the number of firms for each sector.

<b>Industry</b>	<b>Number of firms</b>
<b>Utilities</b>	8
<b>Basic Material</b>	10
<b>Consumer Goods</b>	9
<b>Health Care</b>	9
<b>Industrials</b>	10
<b>Oil and Gas</b>	10
<b>Consumer Services</b>	10
<b>Technology</b>	11
<b>Telecommunications</b>	9

Table 1. Number of firms in each sector

#### 4. Findings

We decompose all time series into 5 scales by employing the MODWT method and then estimate equation (5) at each scale using OLS. Table 2 presents the results for exchange rate exposure at each of the five scales. The table also shows the percentages of firms which have significant positive and negative sensitivity to exchange rate movements at the one percent level of significance. At the 1% level an overall percentage of significant exposure increases across scales. At the 1% level of significance, we find that 11.63% of firms are exposed at scale 1 (2 to 4 month time horizon), 22.09% of firms at scale 2 (4 to 8 month horizon), 40.70% of firms at scale 3 (8 to 16 months), 58.14% of firms at scale 4 (1 year 4 months to 2 years 8 months), and 68.37% of firms at scale 5 (2 years 8 months to 5 years 4 months). As might be expected *a priori*, it is clear that more firms are more exposed at higher scales ( -

lower frequencies, which correspond to longer time horizons).Figure 3 depicts this finding graphically.

Scales	at 1% level
D1	11.63
D2	22.09
D3	40.70
D4	58.14
D5	68.37

Table 2 .Percentage of exposed firms

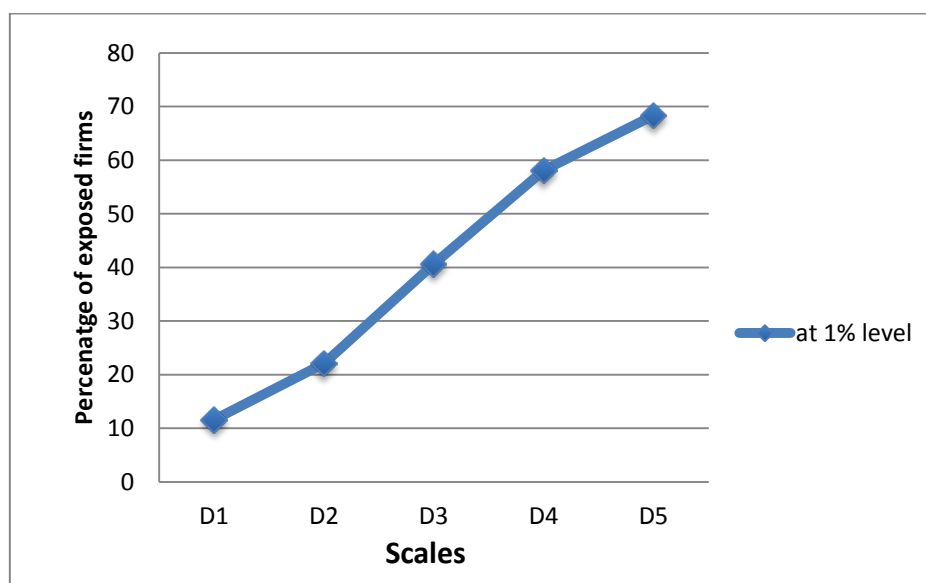

Figure 3. Percentage of exposed firms at different scales

According to Table 3, of the firms with significant exchange rate exposure at scale 1(D=1), 9.30% have a negative coefficient and 2.33% have a positive coefficient. At scale 2, the percentage of firms with a positive coefficient remains constant at 2.33% while the percentage of firms with a negative coefficient increases to 19.77%. The results show that 17.11% of firms are exposed in a positive direction and 23.59% of firms are exposed in a negative direction. This upward trend continues up to scale 5, in a way that the number of firms with a positive exposure increases to 21.10% and 28.04% at scales 4 and 5, respectively. Similarly, the percentage of firms which have negative sensitivity increases to 37.04% and 40.33% at scales 4 and 5, respectively. These findings are shown in Figure 4. It is notable that a positive coefficient means

that firm benefits from an appreciation of the dollar and negative coefficient indicates that firm gains from a depreciation of the dollar.

What is more, firms with significant negative exposure outnumber firms with significant positive exposure. This implies that most firms experience gains when the US dollar depreciates. This finding is somewhat surprising given that the US has run a large trade deficit for many years, but might be due to the fact that firms that importers are more likely to hedge exchange rate risk whereas firms that are export are less likely to hedge in the derivative markets as they can possibly write most of their contracts in US dollar terms.

Scales	Positive%	Negative%
D1	2.33	9.30
D2	2.33	19.77
D3	17.11	23.59
D4	21.10	37.04
D5	28.04	40.33

Table 3. Percentage of Positive and negative exposure coefficients

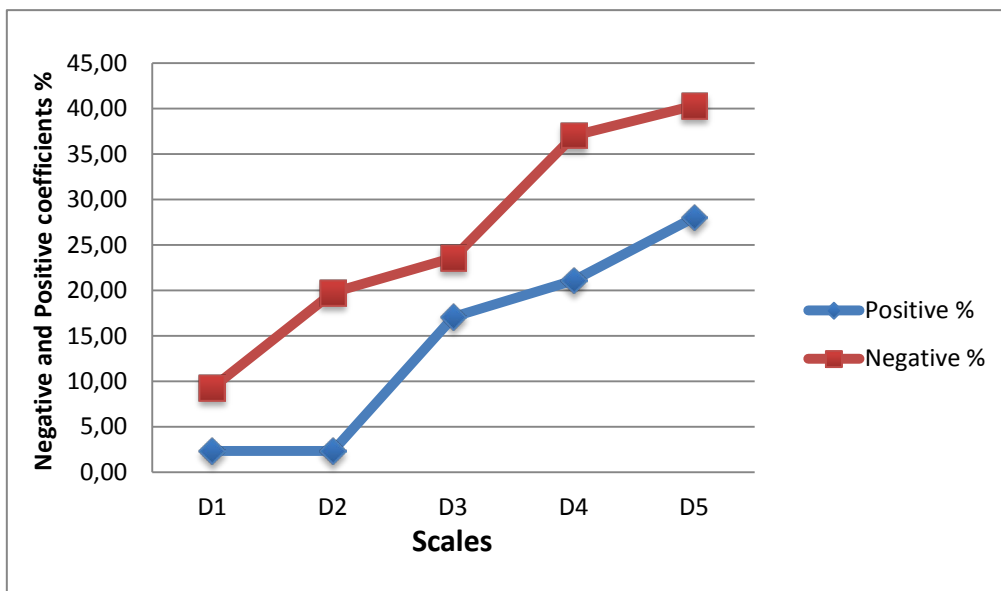

Figure 4. Percentage of negative and positive coefficients

The results stemming from the time-scale regression analysis indicate that average exchange rate exposure coefficients are significantly negative and become stronger as scale increases (Table 4). Furthermore, it should be noted that at the shortest scale

(D1) the effect of exchange rates changes on the firms' return is notably weak (-0.10) in comparison with longer horizons. The exchange rate exposure coefficient increases to -0.42 at scale 2 and gradually reaches to -0.48 at scale. But, it drops to -0.12 at scale 4 and finally increases to -0.54 at scale 5.

These findings are not surprising because the first scale detects mostly noise in the time series; besides, the exchange rate can take time to affect a firm's cash flow and profitability, given that hedging permits most firms to counteract short term movements in exchange rates, but much less so for longer term changes or misalignments. Therefore, it is logical that the longer horizon gives a more accurate picture of the impact of the exchange rate exposure which firms face. Another point is noteworthy, and that is the apparent decline in the average of the exposure coefficients at scale 4 (16-32 months). We note the fact that same firms in the same sector can be exposed in dissimilar ways and have different coefficients at different horizons; hence, on average, some firms with positive exposure may lessen the average sensitivity of firms.<sup>4</sup> It may also be the case that the maximum hedging strategy covers a 2 year horizon so that a decline in exposure at this frequency is observed in the data.

<b>scales</b>	<b>Mean *</b>
<b>D1</b>	<b>-0.10</b>
<b>D2</b>	<b>-0.42</b>
<b>D3</b>	<b>-0.48</b>
<b>D4</b>	<b>-0.12</b>
<b>D5</b>	<b>-0.54</b>

Table 4. Average exchange rate exposure at different scales

\* Significant at 1% level

## 5. Conclusions

In this paper we investigate the effects of exchange rate changes on the stock return of large U.S. firms used a time-frequency methodology, namely discrete wavelet

---

<sup>4</sup> In support of having different sensitivity at same sector, see Dominguez and Tesar (2005).

analysis. We assess the exchange rate exposure over different time horizons by decomposing by frequency range. The study is unique in that other studies to date have employed only time-domain analysis. In this regard, this study, as a first attempt, can shed some light on the scaling properties of the relationship between exchange rate changes and stock returns at different time horizons. Time-frequency analysis enables us to decompose time series into different time scales without losing time related information; so consequently we can provide results over different frequency ranges. We believe that this time-frequency approach is potentially a very interesting avenue for supplementary study into the analysis of exchange rate exposure.

Our findings show that the numbers of firms which are exposed increases as time horizons are extended. To this end, the empirical results reveal that the percentage of firms with positive and negative sensitivity ( - apart from scale 3 - ) increase across scales. The empirical results reveal that at lower frequencies/longer horizons generally the sensitivity to the exchange rate increases, mostly likely because hedging is not available at these longer horizons.

Finally, according to our results, the exchange rate exposure coefficient is stronger at low frequencies or longer horizons for importing firms than for exporting firms in a multi-scale framework. This likely reflects an asymmetry in the usage of hedging strategies between importers and exporters.

## **References**

Adler, M., Dumas, B., 1984. Exposure to Currency Risk: Definition and Measurement. *Financial Management*. pp. 41-50.

Allayannis, G. (1996). Exchange rate exposure revisited. University of Virginia Working paper.

Amihud, Y., 1994. Exchange Rates and the Valuation of Equity Shares, in: Amihud, Y., Levich, R. (Eds), *Exchange Rates and Corporate Performance*, 49-59. Irwin, New York.



Bartov, E. and G.M. Bodnar, 1994, "Firm Valuation, Earnings Expectations, and the Exchange-Rate Exposure Effect," *Journal of Finance*, 1755-1786.

Bartram, S., M., 2004. "Linear and nonlinear foreign exchange rate exposures of German nonfinancial corporations," *Journal of International Money and Finance*, Elsevier, vol. 23(4), pp673-699,

Bartram, Söhnke M. & Bodnar, Gordon, 2005. *The Exchange Rate Exposure Puzzle*. MPRA Paper 6482, University Library of Munich, Germany.

Bodnar, G.M., and W.M. Gentry, 1993. Exchange Rate Exposure and Industry Characteristics: Evidence from Canada, Japan, and the USA, *Journal of International*

Crowley, P. M., 2007. A guide to wavelets for economists. *Journal of Economic Surveys*. Wiley Blackwell, vol. 21(2), pp 207-267, 04

Dominguez, K.M.E., Tesar, L., 2006. Exchange rate exposure. *Journal of International Economics*, vol. 68(1), pp. 188-218.

Donnelly R. and Sheehy E. (1996), "The Share Price Reaction of UK Exporters to Exchange Rate Movements: An Empirical Study", *Journal of International Business Studies*, Vol 27, pp. 157-65.

Gallegati, M., 2008. Wavelet analysis of stock returns and aggregate economic activity, *Computational Statistics & Data Analysis*. Vol. 52, issue 6, pp 3061-3074

Gençay, R., Selçuk, F., Whitcher, B., (2001). Scaling properties of foreign exchange volatility. *Physica A* 289, pp. 249–266.

Griffin, J. M., Stulz, R. M., 2001. International competition and exchange rate shocks: A cross-country industry analysis of stock returns. *Review of Financial Studies* 14, 215-241.

Jorion, P., 1990. The Exchange-Rate Exposure of U.S. Multinationals. *Journal of Business*, pp. 331-345.

Khoo, A. (1994), "Estimation of Foreign Exchange Exposure: An Application to Mining Companies in Australia", *Journal of International Money and Finance*, Vol. 13(3), pp. 342-63.

Kim, S. and In, F., 2005. The relationship between stock returns and inflation: new evidence from wavelet analysis. *Journal of Empirical Finance* Vol 12, Issue 3, pp. 435-444.

Kiyamaz, H. (2003) “Estimation of foreign exchange exposure: an emerging market application”, *Journal of Multinational Financial Management*, 13, 71–84.

Koutmos, G. & A.D. Martin. 2003. A symmetric Exchange Rate Exposure: theory and evidence , *Journal of International Money and Finance*, 22, 365-383.

Mallat, S. G., 1989. A theory for multiresolution signal decomposition: The wavelet representation. *IEEE Transaction on Pattern Analysis and Machine Intelligence*. Vol 11 (7), pp. 674-693.

Mallat, S. G., 1989. Multiresolution approximations and wavelet orthonormal bases of  $L^2(R)$ . *Transaction Of the American Mathematical Society*. Vol 315 (1), pp. 69-87.

*Money and Finance*, vol 12:1, pp. 29-45.

Ramsey, J.B.,2002. Wavelets in Economics and Finance: Past and Future. NYU Working Paper No. S-MF-02-02.

Schleicher, Ch. 2002. An Introduction to Wavelets for Economists. Working Papers 02-3, Bank of Canada.

Strang, G., 1989. Wavelets and dilation equations: A brief introduction. *SIAM Review*. 31 (4), pp. 614-627.

Wang, R. 2012. *Introduction to Orthogonal Transforms*. Cambridge University Press.

Weedon, G. P., 2003. *Time Series Analysis and Cyclostratigraphy: Examining stratigraphic records of environmental cycles*. Cambridge University Press: West Nyack, NY.

Williamson, R.2001. Exchange rate exposure and competition:evidence from the world automotive industry. *Journal of Financial Economic*.59,pp 441–475.

## BANK OF FINLAND RESEARCH DISCUSSION PAPERS

ISSN 1456-6184, online

- 1/2013 Tuomas Takalo **Rationales and instruments for public innovation policies.** 2013. 29 p. ISBN 978-952-462-000-0, online.
- 2/2013 Tuomas Takalo – Tanja Tanayama – Otto Toivanen **Market failures and the additionality effects of public support to private R&D: Theory and empirical implications.** 2013. 40 p. ISBN 978-952-462-001-7, online.
- 3/2013 Martin Ellison – Andreas Tischbirek **Unconventional government debt purchases as a supplement to conventional monetary policy.** 2013. 26 p. ISBN 978-952-462-002-4, online.
- 4/2013 Fabio Verona – Manuel M. F. Martins – Inês Drumond **(Un)anticipated monetary policy in a DSGE model with a shadow banking system.** 2013. 40 p. ISBN 978-952-6699-04-2, online.
- 5/2013 Fabio Verona – Maik H. Wolters **Sticky information models in Dynare.** 2013. 17 p. ISBN 978-952-6699-08-0, online.
- 6/2013 Sami Oinonen – Maritta Paloviita – Lauri Vilmi **How have inflation dynamics changed over time? Evidence from the euro area and USA.** 2013. 36 p. ISBN 978-952-6699-09-7, online.
- 7/2013 Iftekhar Hasan – Matej Marinč **Should competition policy in banking be amended during crises? Lessons from the EU.** 2013. 35 p. ISBN 978-952-6699-10-3, online.
- 8/2013 Bill Francis – Iftekhar Hasan – Qiang Wu **The benefits of conservative accounting to shareholders: Evidence from the financial crisis.** 2013. 44 p. ISBN 978-952-6699-09-7, online.
- 9/2013 Juha Kilponen – Jouko Vilmunen – Oskari Vähämaa **Estimating intertemporal elasticity of substitution in a sticky price model.** 2013. 27 p. ISBN 978-952-6699-12-7, online.
- 10/2013 Owain ap Gwilym – Qingwei Wang – Iftekhar Hasan – Ru Xie **In search of concepts: The effects of speculative demand on returns and volume.** 2013. 35 p. ISBN 978-952-6699-13-4, online.
- 11/2013 Matti Viren **Sensitivity of fiscal-policy effects to policy coordination and business cycle conditions.** 2013. 21 p. ISBN 978-952-6699-20-2, online.
- 12/2013 Seppo Honkapohja **The euro crisis: a view from the North.** 2013. 28 p. ISBN 978-952-6699-23-3, online.
- 13/2013 Stergios Leventis – Iftekhar Hasan – Emmanouil Dedoulis **The cost of sin: The effect of social norms on audit pricing.** 2013. 58 p. ISBN 978-952-6699-27-1, online.
- 14/2013 Chrysovalantis Gaganis – Iftekhar Hasan – Fotios Pasiouras **Efficiency and stock returns: Evidence from the insurance industry.** 2013. 33 p. ISBN 978-952-6699-28-8, online.

- 15/2013 Chung-Hua Shen – Iftekhar Hasan – Chih-Yung Lin **The government's role in government-owned banks.** 2013. 51 p. ISBN 978-952-6699-29-5, online.
- 16/2013 Fabio Verona **Lumpy investment in sticky information general equilibrium.** 2013. 37 p. ISBN 978-952-6699-30-1, online.
- 17/2013 Jouko Vilmunen – Peter Palmroos **Closed form solution of correlation in doubly truncated or censored sample of bivariate log-normal distribution.** 2013. 9 p. ISBN 978-952-6699-31-8, online.
- 18/2013 Fabio Verona **Investment dynamics with information costs.** 2013. 38 p. ISBN 978-952-6699-34-9, online.
- 19/2013 Mervi Toivanen **Contagion in the interbank network: an epidemiological approach.** 2013. 41 p. ISBN 978-952-6699-35-6, online.
- 20/2013 Jagjit S. Chadha – Elisa Newby **Midas, transmuting all, into paper: The Bank of England and the Banque de France during the Revolutionary and Napoleonic Wars.** 2013. 54 p. ISBN 978-952-6699-38-7, online.
- 21/2013 Kimmo Ollikka – Janne Tukiainen **Central bank liquidity auction mechanism design and the interbank market.** 2013. 47 p. ISBN 978-952-6699-39-4, online.
- 22/2013 Daron Acemoglu – Ufuk Akcigit – Nicholas Bloom – William Kerr **Innovation, reallocation and growth.** 2013. 47 p. ISBN 978-952-6699-40-0, online.
- 23/2013 Iftekhar Hasan – Jonathan O'Brien – Pengfei Ye **What types of bondholders impede corporate innovative activities?** 2013. 51 p. ISBN 978-952-6699-42-4, online.
- 24/2013 Jussi Lintunen – Lauri Vilmi **On optimal emission control – Taxes, substitution and business cycles.** 2013. 30 p. ISBN 978-952-6699-43-1, online.
- 25/2013 Ilkka Kiema – Esa Jokivuolle **99.9% – really?** 2013. 42 p. ISBN 978-952-6699-44-8, online.
- 26/2013 Pentti Saikkonen – Rickard Sandberg **Testing for a unit root in noncausal autoregressive models.** 2013. 29 p. ISBN 978-952-6699-45-5, online.
- 27/2013 Bill B. Francis – Iftekhar Hasan – Yun Zhu **The impact of political uncertainty on institutional ownership.** 2013. 55 p. ISBN 978-952-6699-48-6, online.
- 28/2013 Ufuk Akcigit – William R. Kerr **Growth through heterogeneous innovations.** 2013. 80 p. ISBN 978-952-6699-49-3, online.
- 29/2013 Bill B. Francis – Iftekhar Hasan – Yun Zhu **Managerial style and bank loan contracting.** 2013. 42 p. ISBN 978-952-6699-50-9, online.
- 30/2013 Ant Bozkaya – William R. Kerr **Labor regulations and European venture capital.** 2013. 50 p. ISBN 978-952-6699-51-6, online.
- 31/2013 William R. Kerr **Income inequality and social preferences for redistribution and compensation differentials.** 2013. 48 p. ISBN 978-952-6699-52-3, online.

- 32/2013 Kai Christoffel – Ivan Jaccard – Juha Kilponen **Welfare and bond pricing implications of fiscal stabilization policies.** 2013. 45 p. ISBN 978-952-6699-54-7, online.
- 33/2013 Patrick M. Crowley – Enrique Garcia – Chee-Heong Quah **Is Europe growing together or growing apart?** 2013. 31 p. ISBN 978-952-6699-55-4, online.
- 34/2013 Patrick M. Crowley – Amir Habibdoust **Assessing the exchange rate exposure of US multinationals.** 2013. 17 p. ISBN 978-952-6699-56-1, online.

